

Important

EGTs are sensitive, high accuracy instruments. They must be handled and installed with care to insure proper performance. Carefully read and follow these instructions, and your EGT will provide you with a long and accurate life.

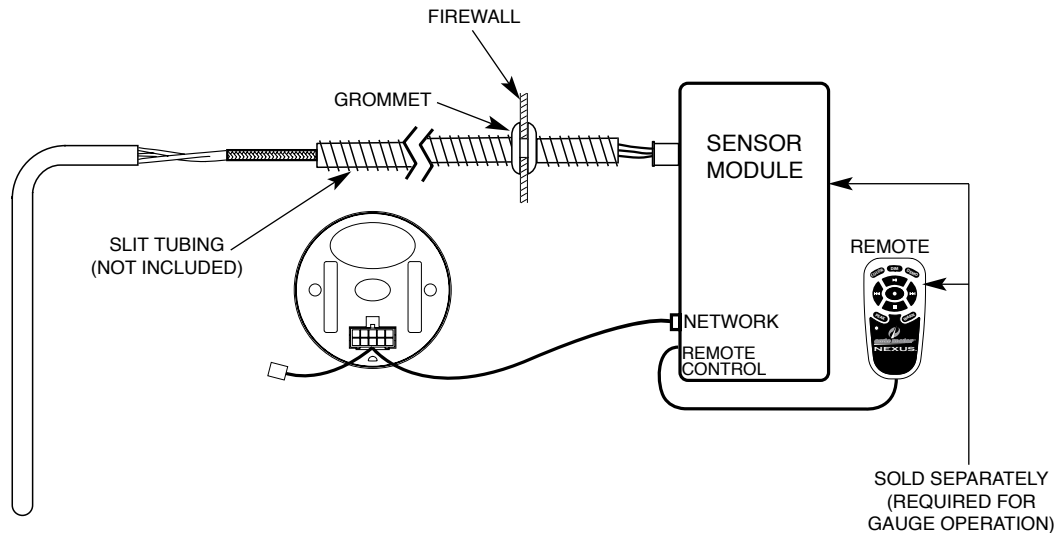

Connect gauge to sensor module
Network connection
(Single gauge hook-up)



OR

Connect gauge to the last gauge in the series
(Multi gauge hook-up)

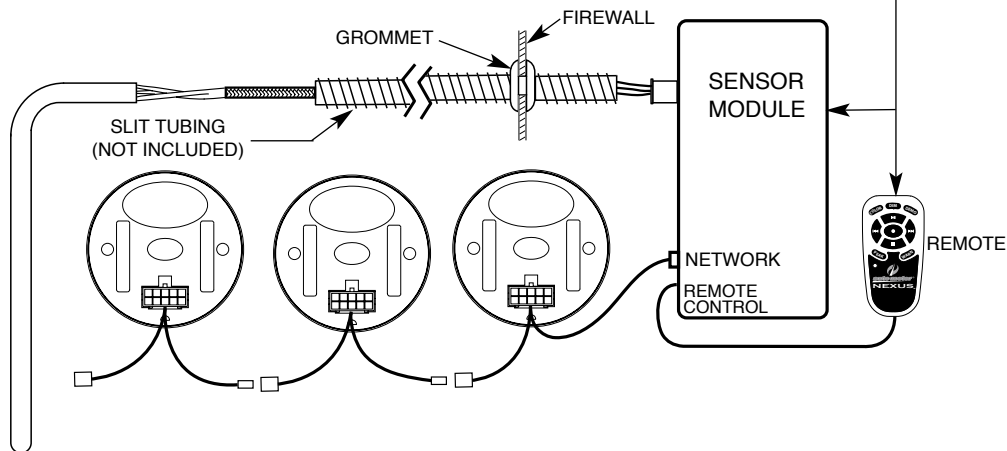

Installation

1. Check that you have all parts required for installation and the engine is cool.
2. Disconnect the negative (-) battery cable.
3. Gauge mounts in a 2 1/16" hole. If mounting in-dash, use the supplied threaded studs, mounting bracket and hardware to secure gauge to dash. Thread short end of threaded stud into the two holes in the back of the case until the hex flat is seated against the back of the case. **DO NOT OVER-TIGHTEN.**
4. Drill 1" diameter hole where wires pass through sheet metal (such as firewall) and install the provided rubber grommet.
5. If connecting gauge in line with other gauges, use the supplied 12" wire harness, connecting the black connector to the back port on the gauge and the white four-pin female connector to the mating white connector on the adjacent gauge wire harness.

If the gauge is the first in the series, use the 6' wire harness supplied with the Sensor Module Control and Remote Control. Plug the white four-pin female connector at one end of the wire harness to the port on the Sensor Module labeled "NETWORK" and the black connector at the other end to the back port on the gauge.

6. Reconnect negative (-) battery cable.

Probe Installation

1. Begin by installing the thermocouple in the exhaust, then work back to the Sensor Module. Installing the probe in the proper location will insure optimal temperature readings. For non-turbo engines, install the probe 1-2 inches from the cylinder head. For turbo engines, remove the exhaust manifold and install the probe 1-2 inches from the cylinder head. If the exhaust manifold can not be removed, install the probe 1-2 inches after the turbo exhaust outlet (Exhaust gas temps could drop over 200° when installing after the turbo). **CLEAN ALL METAL FILINGS** out of the exhaust manifold. Metal filings will damage the turbo impellor if they go through the turbo.

The probe can be mounted in two different ways, so please use the method best suited for your needs.

- A) **Pre-existing 1/8" NPT Threaded Hole:** Simply screw the threaded fitting into the hole, insert the probe, and tighten the set screw snugly onto the probe. (Caution: do not over tighten set screw or damage to probe may occur.) Make sure the probe is oriented so the wires do not come in contact with, or become too close to the manifold or other hot engine parts. See illustration for details.
 - B) **Stainless Clamp Method:** This method is for applications that require frequent removal of the manifold or header for service, or just faster and easier installation. Drill a 7/16" diameter hole about 6" down from the junction of the exhaust pipe to manifold junction. Undo the clamp and slide the probe into the hole in the clamp. Slide the set screw collar onto the probe. Before tightening the collar in position make sure that when inserted, the probe will have its tip in the middle two-thirds of the exhaust stream. Tighten screw collar in position. (Caution: do not over tighten set screw or damage to probe may occur.) Hold the clamp open when inserting the probe into the 13/32" hole. Re-join the clamp ends and tighten in position. Make sure the probe is oriented so the wires do not come in contact with, or become too close to the manifold or other hot engine parts. See the illustration below for details.
2. With the probe installed, the wire harness can now be routed to the Sensor Module to port labeled "EGT". The wire harness is an integral part of the EGT calibration. It may not be shortened or lengthened without affecting the gauge calibration. You will need to determine a suitable location to coil the excess wire, and tie it loosely with a wire tie. (Loosely tying the excess coil prevents embrittlement caused by vibration.) Pass the harness through the fire wall using an existing hole, or drill a 1" diameter hole and use the rubber grommet provided to protect the wire from damage.

A. Pre-existing 1/8" NPT Threaded Hole

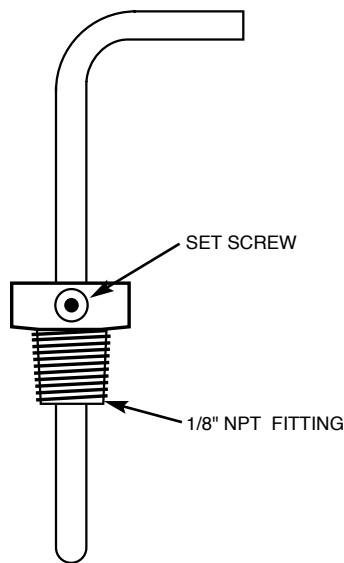

B. Stainless Clamp Method

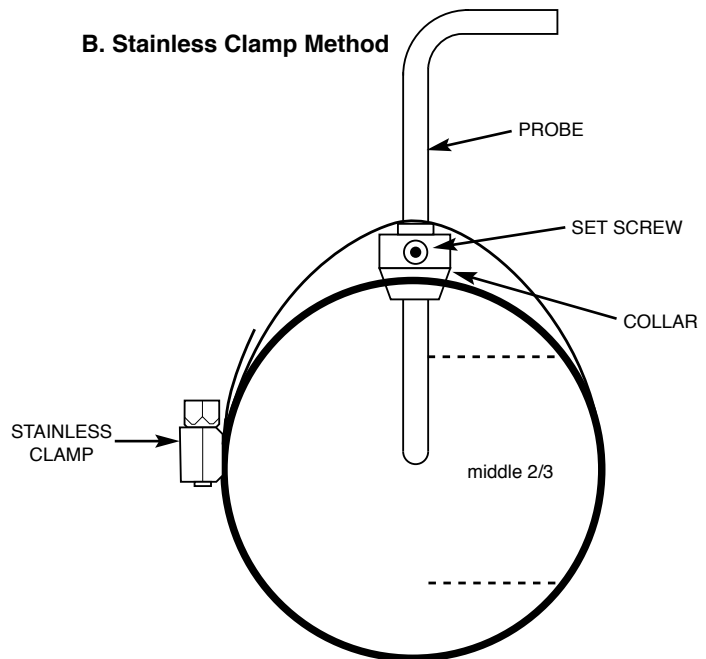

SERVICE

For service send your product to Auto Meter in a well packed shipping carton. Please include a note explaining what the problem is along with your phone number. Please specify when you need the product back. If you need it back immediately mark the outside of the box "RUSH REPAIR," and Auto Meter will service product within two days after receiving it. (\$10.00 charge will be added to the cost of "RUSH REPAIR.") If you are sending product back for Warranty adjustment, you must include a copy (or original) of your sales receipt from the place of purchase.

12 MONTH LIMITED WARRANTY

Auto Meter Products, Inc. warrants to the consumer that all Auto Meter High Performance products will be free from defects in material and workmanship for a period of twelve (12) months from date of the original purchase. Products that fail within this 12 month warranty period will be repaired or replaced at Auto Meter's option to the consumer, when it is determined by Auto Meter Products, Inc. that the product failed due to defects in material or workmanship. This warranty is limited to the repair or replacement of parts in the Auto Meter instruments. In no event shall this warranty exceed the original purchase price of the Auto Meter instruments nor shall Auto Meter Products, Inc. be responsible for special, incidental or consequential damages or costs incurred due to the failure of this product. Warranty claims to Auto Meter must be transportation prepaid and accompanied with dated proof of purchase. This warranty applies only to the original purchaser of product and is non-transferable. All implied warranties shall be limited in duration to the said 12 month warranty period. Breaking the instrument seal, improper use or installation, accident, water damage, abuse, unauthorized repairs or alterations voids this warranty. Auto Meter Products, Inc. disclaims any liability for consequential damages due to breach of any written or implied warranty on all products manufactured by Auto Meter.

FOR SERVICE SEND TO: AUTO METER PRODUCTS, INC. 413 W. Elm St., Sycamore, IL 60178 USA (815) 899-0801

Email us at service@autometer.com