

# INSTALLATION INSTRUCTIONS

## PEDESTAL ELECTRIC TACHOMETERS

2650-1182



### QUESTIONS:

If after completely reading these instructions you have questions regarding the operation or installation of your instrument(s), please contact Auto Meter Technical Service at **815-899-0801**.

You may also email us at [service@autometer.com](mailto:service@autometer.com).

Additional information can also be found at [http://www.autometer.com/tech\\_faq.aspx](http://www.autometer.com/tech_faq.aspx)

### IMPORTANT

This tachometer is factory calibrated to operate on 8 cylinder engines. For 4 or 6 cylinder engines, it is necessary to make the proper adjustments to adapt this tachometer to your cylinder range.

### NOTE:

This tachometer has an air core meter. The tach pointer may not always rest at zero. This is normal. When engine is started, pointer will position on the correct RPM.

### 5" TACHOMETER CALIBRATION

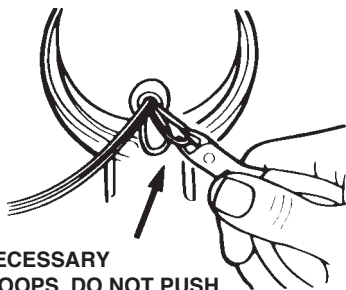

CLIP NECESSARY  
WIRE LOOPS. DO NOT PUSH  
WIRES INTO CASE.

**8 CYL.**—NO adjustment is necessary.

**6 CYL.**—Clip BROWN wire loop only.  
Insulate with electrical tape.

**4 CYL.**—Clip BROWN and ORANGE  
wire loops. Insulate with  
electrical tape.

### 3 3/4" TACHOMETER CALIBRATION

The switch to change tachometer calibration is inside the tachometer and is accessible via the light hole on the back of the tachometer. The switch is located to the left of the light socket. Adjust switch with a small screw driver or unwound paper clip.

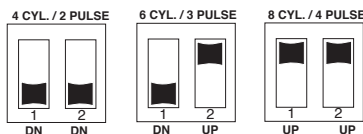

8 CYL. - Both switches up.

6 CYL. - Switch One down, Switch Two up.

4 CYL. - Both switches down.

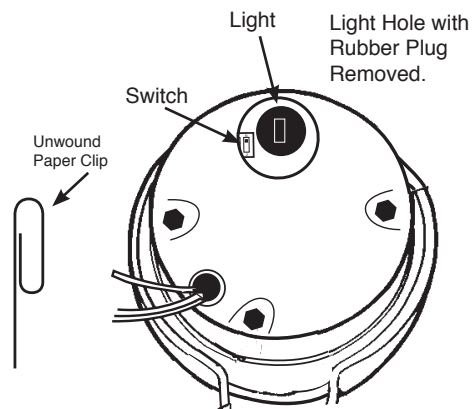

### Mounting

The special design of the tachometer base allows for a variety of mounting possibilities. Attach the base using screws provided or use pop rivet tool.

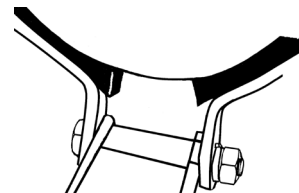

## Wiring (5" Tachometer shown)

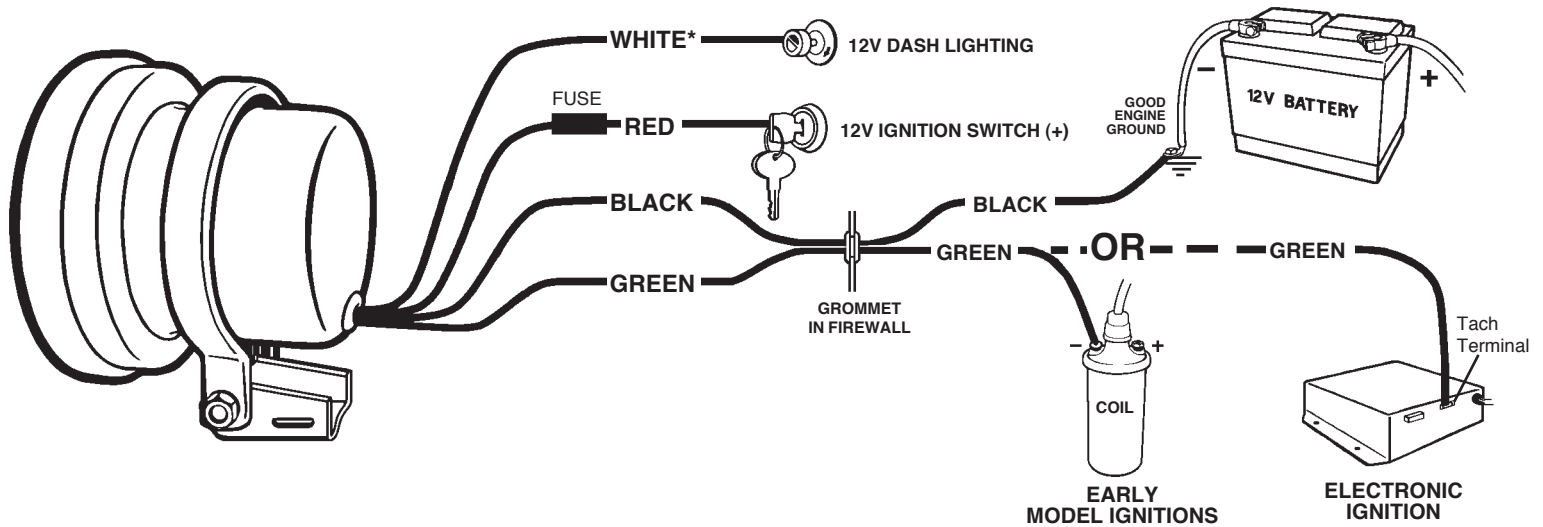

### CAUTION!

As a safety precaution, the +12 V terminal of this product should be fused before connecting it to the 12V ignition switch. We recommend using a 4 Amp, 3 AG fast-acting type cartridge fuse (Littlefuse® #312 004 or an equivalent).

### WARNING

Warranty will be void if connected to coil when using an aftermarket ignition box such as, but not limited to products from the following manufacturers: MSD, Crane, Jacobs, Mallory, Holley, Etc.. Prior to installation of your tachometer, check with the ignition box manufacturer for recommended tachometer signal location.

### Light Replacement for 5" Tachs

Rotate twist-lock socket counterclockwise and remove. Replace the old bulb with Auto Meter No. 3218 or GE86 Bulb.

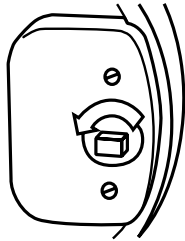

### Light Replacement for 3 3/4" Tachs

Remove rubber plug. Rotate twist-lock socket counterclockwise using needle nose pliers and remove. Replace old bulb with GE 194 bulb.

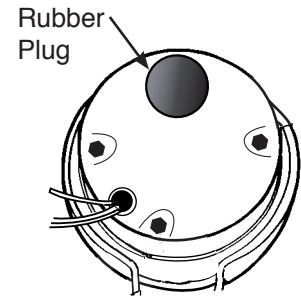

**NOTE: This tachometer operates on most early model ignitions, factory electronic and high performance electronic racing ignitions, such as Hy Fire, Crane, and MSD.**

### SERVICE

For service send your product to Auto Meter in a well packed shipping carton. Please include a note explaining what the problem is along with your phone number. Please specify when you need the product back. If you need it back immediately mark the outside of the box "RUSH REPAIR," and Auto Meter will service product within two days after receiving it. (\$10.00 charge will be added to the cost of "RUSH REPAIR.") If you are sending product back for Warranty adjustment, you must include a copy (or original) of your sales receipt from the place of purchase.

### 12 MONTH LIMITED WARRANTY

Auto Meter Products, Inc. warrants to the consumer that all Auto Meter High Performance products will be free from defects in material and workmanship for a period of twelve (12) months from date of the original purchase. Products that fail within this 12 month warranty period will be repaired or replaced at Auto Meter's option to the consumer, when it is determined by Auto Meter Products, Inc. that the product failed due to defects in material or workmanship. This warranty is limited to the repair or replacement of parts in the Auto Meter instruments. In no event shall this warranty exceed the original purchase price of the Auto Meter instruments nor shall Auto Meter Products, Inc. be responsible for special, incidental or consequential damages or costs incurred due to the failure of this product. Warranty claims to Auto Meter must be transportation prepaid and accompanied with dated proof of purchase. This warranty applies only to the original purchaser of product and is non-transferable. All implied warranties shall be limited in duration to the said 12 month warranty period. Breaking the instrument seal, improper use or installation, accident, water damage, abuse, unauthorized repairs or alterations voids this warranty. Auto Meter Products, Inc. disclaims any liability for consequential damages due to breach of any written or implied warranty on all products manufactured by Auto Meter.

FOR SERVICE SEND TO: **AUTO METER PRODUCTS, INC.** 413 W. Elm St., Sycamore, IL 60178 USA (815) 899-0801  
Email us at [service@autometer.com](mailto:service@autometer.com)