

INSTALLATION INSTRUCTIONS



1917 Oak Park Blvd • Pleasant Hill, CA 94523
(925)935-3025 • Fax (925)935-2287
www.dedenbear.com • email@dedenbear.com

Air Shifter Kit
For Pro Bandit
Model:
B&MPBASK

INSTALLATION

1. Install the 1/8" pipe nipple in the "CYL" port on the air solenoid using thread sealant.
2. Install the right angle quick disconnect fitting in the "IN" port on the air solenoid.
3. Screw the complete assembly in to the B&M air cylinder.
4. Choose the appropriate wiring diagram from the reverse side and wire as shown.
5. Plumb the solenoid using 1/4" o.d. nylon tubing, simply push the tubing into the quick disconnect fitting to install. To remove, push on the plastic lock ring while pulling on the tubing.
6. Set the line pressure to 80 psi.

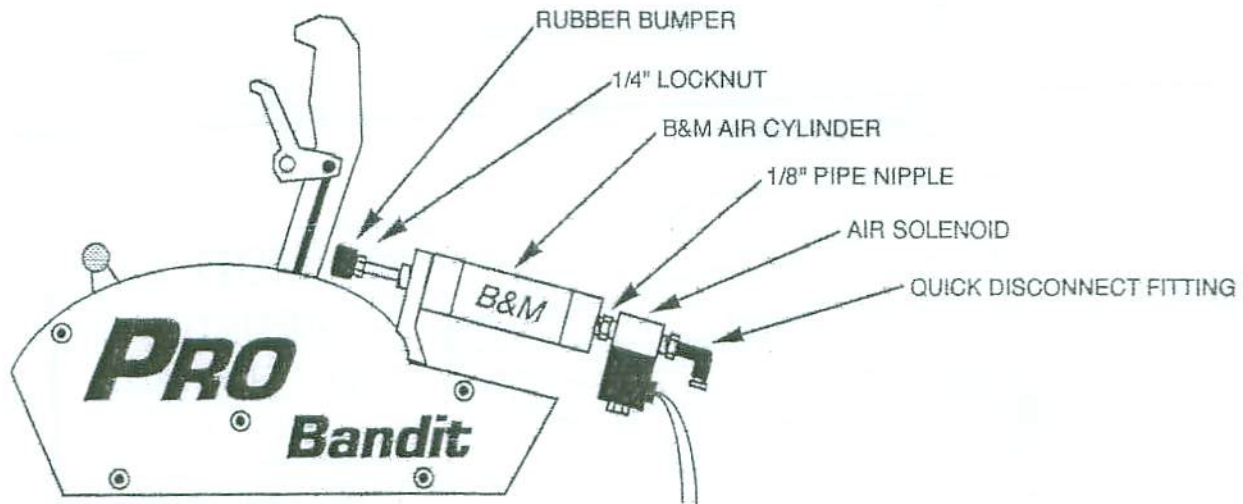

LIMITED 1 YEAR WARRANTY

Dedenbear Products components are warranted directly by Dedenbear Products against defective material or workmanship under normal use and service for a period of one (1) year after purchase. Dedenbear Products will repair or replace the defective unit, at Dedenbear Products option, free of charge. This warranty does not cover any damage to the component caused by abuse, mishandling, alteration, accident, electrical current fluctuations, failure to follow installation/operating instructions, maintenance, storage and environmental conditions, or repair attempts made anyone other than Dedenbear Products Authorized Service facility.

DEDENBEAR PRODUCTS SHALL NOT BE LIABLE FOR INJURY, CONSEQUENTIAL, OR OTHER TYPE DAMAGES RESULTING FROM THE USE OF ITS PRODUCTS, OTHER THAN THE LIABILITY STATED ABOVE. This warranty is in lieu of all other warranties of merchantability or fitness of use. This warranty gives you specific legal rights, and you may also have other rights which vary from state to state.

For Service on all Dedenbear Products, return directly to: DEDENBEAR PRODUCTS, INC. • ATTN: REPAIRS • 1917 OAK PARK BLVD. • PLEASANT HILL, CA 94523. For faster service, please include a note describing the nature of the problem, a copy of your original invoice, your name, return shipping address, and daytime & evening phone numbers where you can be reached.

WIRING WITH DEDENBEAR RPM-2

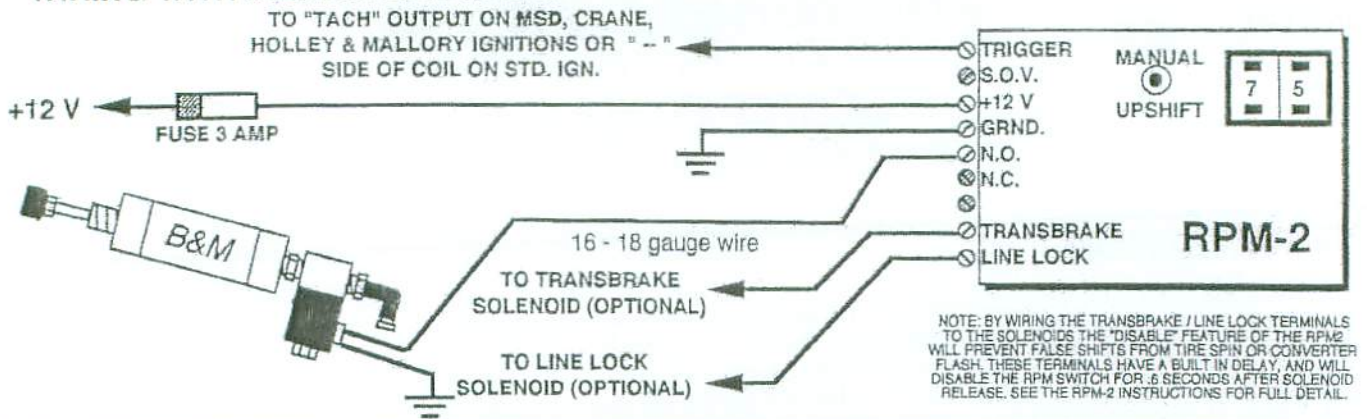

WIRING WITH DEDENBEAR CC-1, BM-1, CC-2 OR BM-2

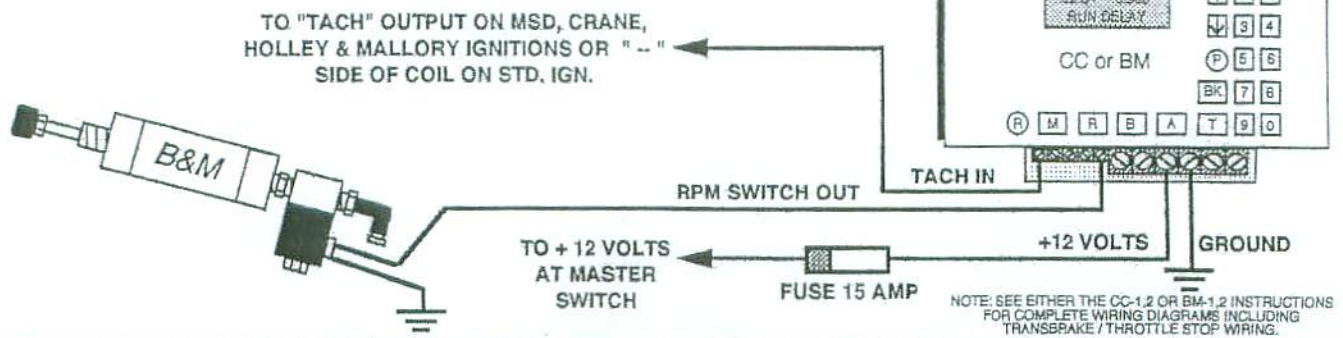

WIRING WITH MSD RPM SWITCH #8950

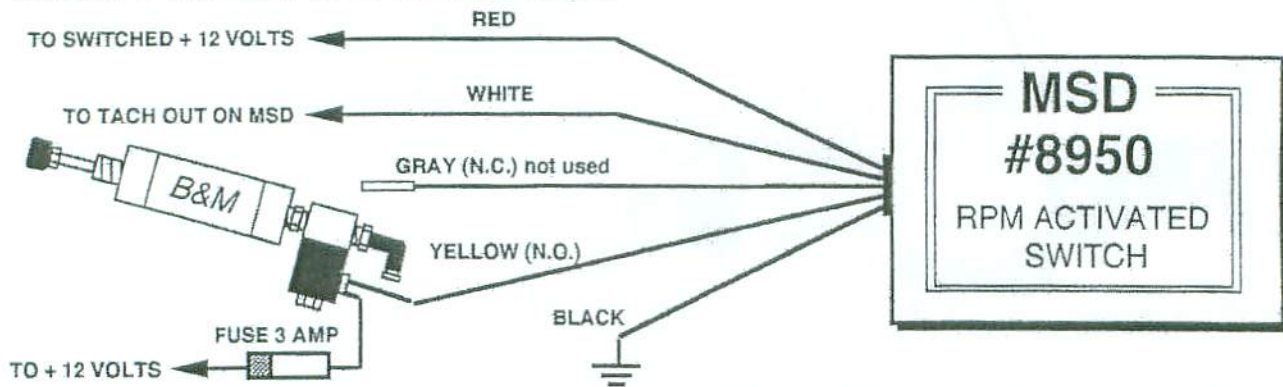

WIRING WITH MSD 7AL3 IGNITION

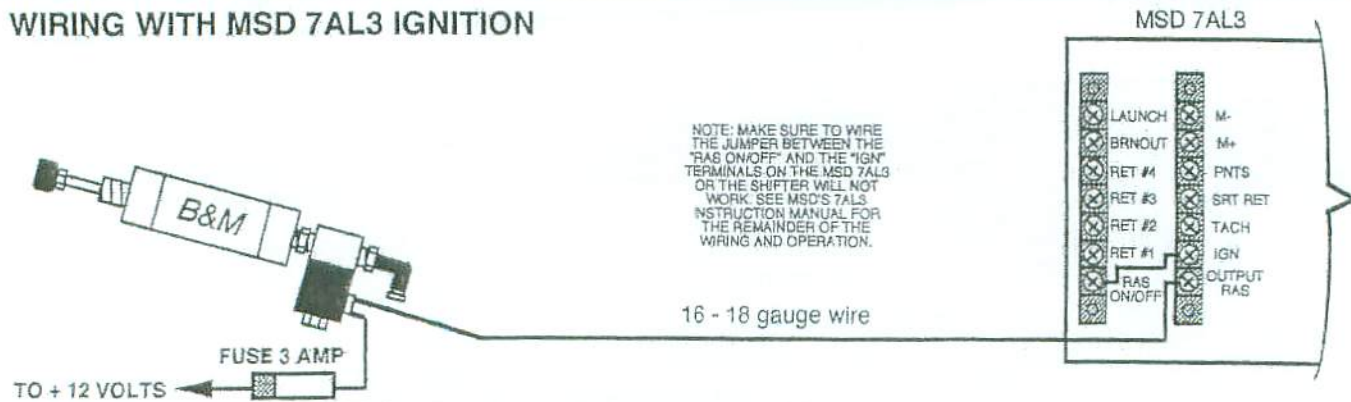

NOTE: IF YOUR DIAGRAM IS NOT SHOWN, CALL (925) 935-3025 FOR TECHNICAL HELP